

OCR Further Pure 1

Complex Numbers

Section 3: Modulus and argument

Multiple Choice Test

1) The modulus of the complex number $z = 2 - 5i$ is

- (a) $\sqrt{7}$ (b) 29
(c) 7 (d) $\sqrt{29}$
(e) I don't know

2) The set of points for which $|z - 2 + 3i| = 4$ is

- (a) a circle, centre $-2 + 3i$, radius 2 (b) a circle, centre $2 - 3i$, radius 2
(c) a circle, centre $-2 + 3i$, radius 4 (d) a circle, centre $2 - 3i$, radius 4
(e) I don't know

3)

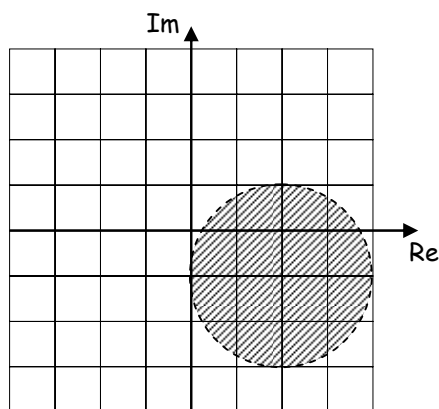

The shaded area in the Argand diagram represents the points z for which

- (a) $|z - 2 + i| \leq 2$ (b) $|z - 2 + i| < 2$
(c) $|z + 2 - i| < 2$ (d) $|z + 2 - i| \leq 2$
(e) I don't know

OCR Further Pure 1

4)

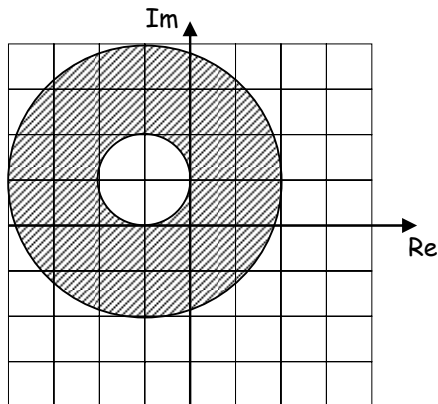

The shaded area in the Argand diagram above represents the points z for which

- (a) $2 \leq |z + 1 - i| \leq 6$ (b) $1 \leq |z + 1 - i| \leq 3$
(c) $2 \leq |z - 1 + i| \leq 6$ (d) $1 \leq |z - 1 + i| \leq 3$
(e) I don't know

5) The principal argument of the complex number $-1 + \sqrt{3}i$ is

- (a) $\frac{2\pi}{3}$ (b) $-\frac{2\pi}{3}$
(c) $\frac{\pi}{3}$ (d) $-\frac{\pi}{3}$
(e) I don't know

6) The principal argument of the complex number $2 - 2i$ is

- (a) $-\frac{\pi}{4}$ (b) $-\frac{3\pi}{4}$
(c) $\frac{\pi}{4}$ (d) $\frac{3\pi}{4}$
(e) I don't know

7) The complex number with modulus 2 and argument -1.5 is

- (a) $-0.14 + 1.99i$ (b) $1.99 - 0.14i$
(c) $0.14 - 1.99i$ (d) $-1.99 + 0.14i$
(e) I don't know

OCR Further Pure 1

8)

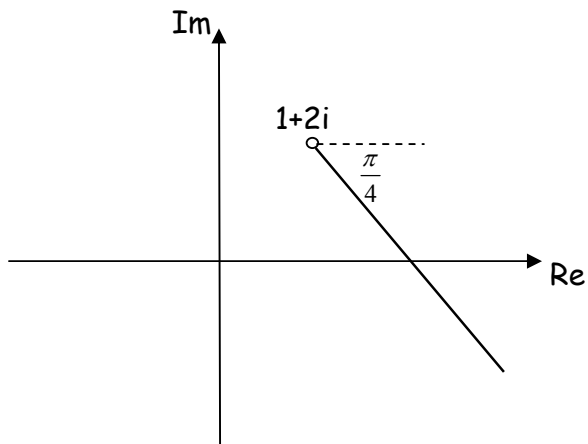

The bold half-line in the diagram above shows the set of points z for which

(a) $\arg(z + 1 + 2i) = \frac{\pi}{4}$

(b) $\arg(z - 1 - 2i) = \frac{\pi}{4}$

(c) $\arg(z + 1 + 2i) = -\frac{\pi}{4}$

(d) $\arg(z - 1 - 2i) = -\frac{\pi}{4}$

(f) I don't know

9)

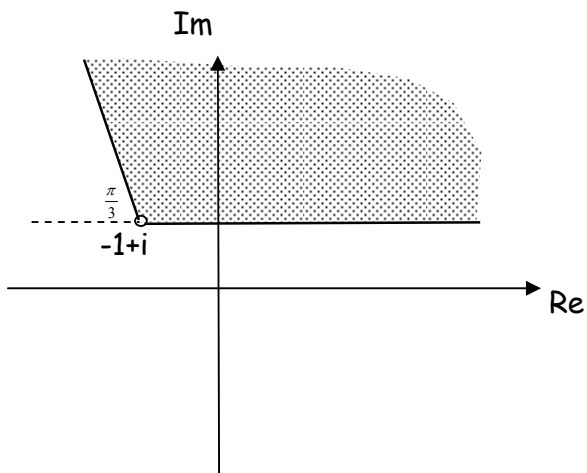

The shaded area in the diagram above shows the set of points z for which

(a) $0 \leq \arg(z + 1 - i) \leq \frac{2\pi}{3}$

(b) $\arg(z - 1 + i) \leq \frac{2\pi}{3}$

(c) $0 \leq \arg(z - 1 + i) \leq \frac{2\pi}{3}$

(d) $\arg(z + 1 - i) \leq \frac{2\pi}{3}$

(f) I don't know

OCR Further Pure 1

10)

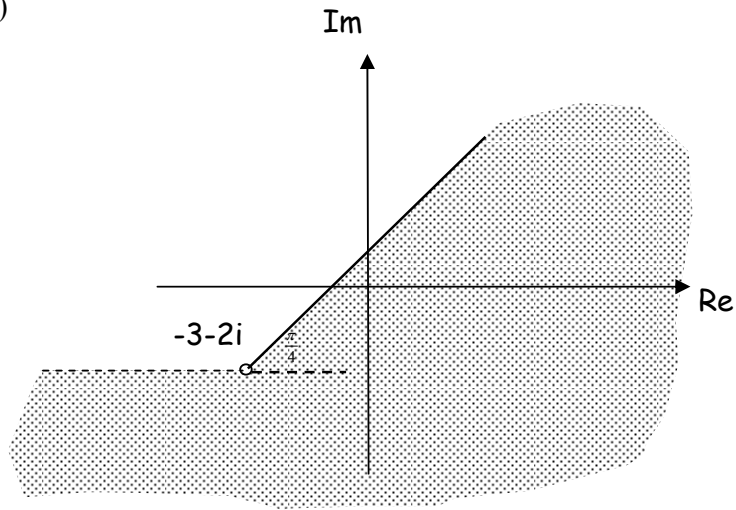

The shaded area in the diagram above shows the set of points z for which

(a) $\arg(z - 3 - 2i) \geq \frac{\pi}{4}$

(b) $\arg(z - 3 - 2i) \leq \frac{\pi}{4}$

(c) $\arg(z + 3 + 2i) \geq \frac{\pi}{4}$

(d) $\arg(z + 3 + 2i) \leq \frac{\pi}{4}$

(e) I don't know

OCR Further Pure 1

Solutions to Multiple Choice Test

1) The correct answer is d)

$$|2 - 5i| = \sqrt{2^2 + 5^2} = \sqrt{29}$$

2) The correct answer is d)

$$|z - 2 + 3i| = 4$$

$$|z - (2 - 3i)| = 4$$

This means that the distance of the point representing z from the point representing $2 - 3i$ is always 4.

So this is a circle, centre $2 - 3i$, radius 4.

3) The correct answer is b)

The shaded area shows points inside a circle, centre $2 - i$, radius 2.

The dotted line indicates that the circumference of the circle is not included.

So the shaded area represents the points z whose distance from the point $2 - i$ is less than 2.

i.e. $|z - (2 - i)| < 2$

$$|z - 2 + i| < 2$$

4) The correct answer is b)

The shaded area shows points whose distance from the point $-1 + i$ is between 1 and 3 inclusive.

i.e. $1 \leq |z - (-1 + i)| \leq 3$

$$1 \leq |z + 1 - i| \leq 3$$

OCR Further Pure 1

5) The correct answer is a)

$$z = -1 + \sqrt{3}i$$

$$\cos \theta = \frac{-1}{\sqrt{1+3}} = -\frac{1}{2}$$

$$\sin \theta = \frac{\sqrt{3}}{\sqrt{1+3}} = \frac{\sqrt{3}}{2}$$

Since θ is in the second quadrant, $\theta = \frac{2\pi}{3}$.

6) The correct answer is a)

$$z = 2 - 2i$$

$$\cos \theta = \frac{2}{\sqrt{4+4}} = \frac{2}{2\sqrt{2}} = \frac{1}{\sqrt{2}}$$

$$\sin \theta = \frac{-2}{\sqrt{4+4}} = -\frac{2}{2\sqrt{2}} = -\frac{1}{\sqrt{2}}$$

Since θ is in the fourth quadrant, $\theta = -\frac{\pi}{4}$.

7) The correct answer is c)

$$\text{Let } z = x + iy$$

$$|z| = 2 \Rightarrow x^2 + y^2 = 2$$

$$\cos \theta = \frac{x}{2} \Rightarrow x = 2 \cos \theta = 2 \cos(-1.5) = 0.14 \text{ (2 d.p.)}$$

$$\sin \theta = \frac{y}{2} \Rightarrow y = 2 \sin \theta = 2 \sin(-1.5) = -1.99 \text{ (2 d.p.)}$$

The complex number with modulus 2 and argument -1.5 is $0.14 - 1.99i$

8) The correct answer is d)

The line starts from the point $1 + 2i$ and goes in the direction $-\frac{\pi}{4}$.

$$\text{The set of points is therefore } \arg(z - (1 + 2i)) = -\frac{\pi}{4}$$

$$\arg(z - 1 - 2i) = -\frac{\pi}{4}$$

OCR Further Pure 1

9) The correct answer is a)

The lines bounding the region both start from the point $-1 + i$ and have directions 0 and $\frac{2\pi}{3}$ respectively.

These lines are given by $\arg(z + 1 - i) = 0$ and $\arg(z + 1 - i) = \frac{2\pi}{3}$.

So the shaded region is given by

$$0 \leq \arg(z + 1 - i) \leq \frac{2\pi}{3}$$

10) The correct answer is d)

The solid line bounding the region starts from the point $-3 - 2i$ and has direction $\frac{\pi}{4}$, so this line is given by $\arg(z + 3 + 2i) = \frac{\pi}{4}$.

The region includes all points for which $\arg(z + 3 + 2i)$ is any number from $\frac{\pi}{4}$ down to the smallest possible value for an argument, i.e. just above $-\pi$.

So the shaded region is given by

$$\arg(z + 3 + 2i) \leq \frac{\pi}{4}$$